

American Champion Aircraft Corp.
Rochester, WI 53167

Service Letter: 422 Revision "A" (Page 1 of 4)

Date: January 14, 2005

Title: Aluminum Gear Retrofit

Models: Bellanca/American Champion 7ECA, 7GCAA, 7GCBC, 7KCAB, 8KCAB, 8GCBC

Description: Aluminum gear retrofit requires replacing the existing fairing tube, rerouting brake lines, and modifying the wheel pant cutout.

Procedure:

1. Refer to Service Manual for jacking of aircraft and procedure for removal of the old main landing gear leg assembly.
2. Remove fabric to expose 1-9998 fairing tube.
3. Remove 1-9998 tube, cut and grind flush to fuselage frame and 4-1484 fairing tube.
4. Grind 1-9998-1 tube to mate with fuselage frame.
5. Install 1-9998-1 tube per figure 1, weld per Champion Specification CW-1 or other industry accepted process for tubular steel welding.

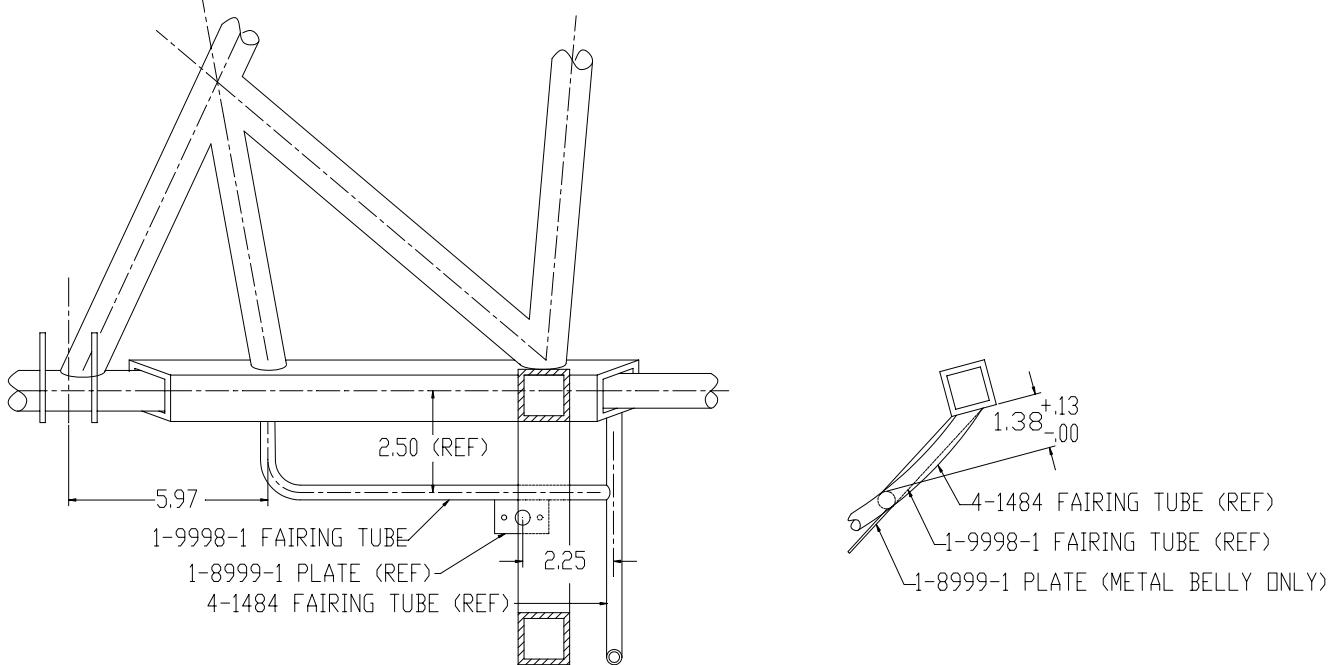

Figure 1, 1-9998-1 Fairing Tube Installation

6. If metal belly installed, install 1-8999-1 plate per figure 1, weld per CW-1 or other industry accepted process for tubular steel welding.
7. Treat all bare surfaces with zinc-chromate primer or equivalent.
8. Patch fabric and repaint in accordance with applicable ACAC service manual.

**American Champion Aircraft Corp.
Rochester, WI 53167**

Service Letter: 422 Revision "A" (Page 2 of 4)

Date: January 14, 2005

Title: Aluminum Gear Retrofit

9. If metal belly installed, modify 3-1498 skin per figure 2.

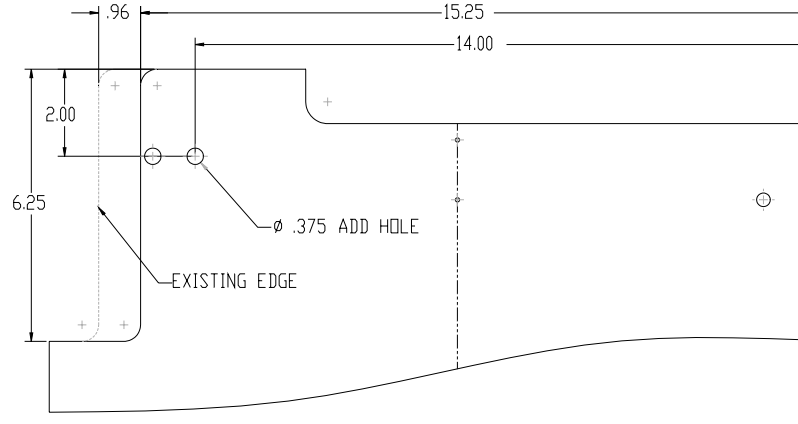

Figure 2, 3-1498 Skin Cutout

- 10. Install aluminum gear legs per ACAC drawing 7-1559 (no rev. or later) for all models except 8GCBC, for 8GCBC install per ACAC drawing 7-1579 (no rev. or later).
- 11. Remove 2-2111-8 (7-Series and 8KCAB) or 2-2133-2 (8GCBC) brake line and hardware and install 9563K84 snap plug in boot cowl.
- 12. Install 2-2111-9 brake line per figure 3.

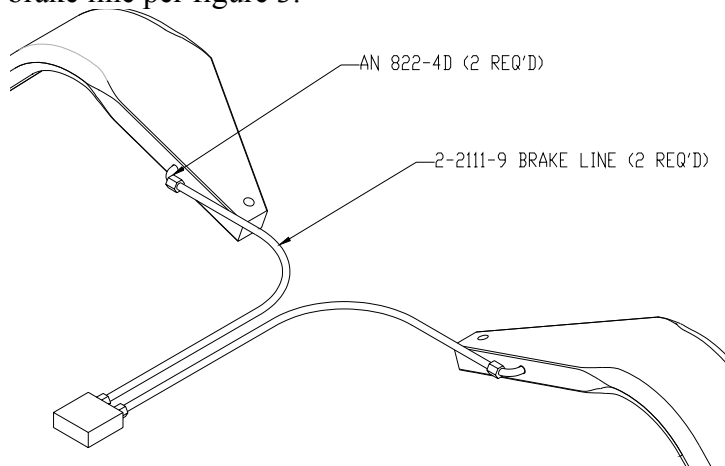

Figure 3, 2-2111-9 Brake Line Installation

**American Champion Aircraft Corp.
Rochester, WI 53167**

Service Letter: 422 Revision "A" (Page 3 of 4)

Date: January 14, 2005

Title: Aluminum Gear Retrofit

13. Modify wheel pant (Part Number 7-1541 L/R) per figure 4.

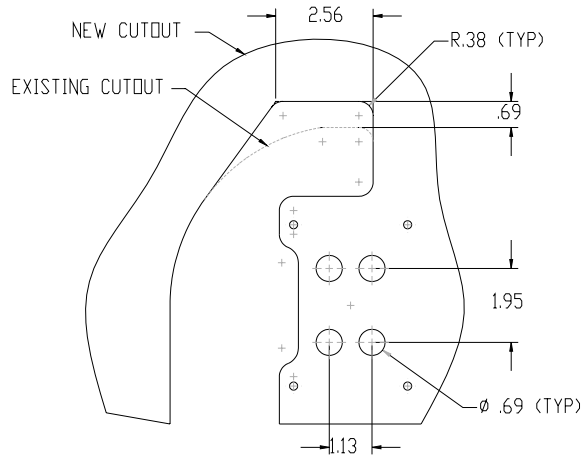

Figure 4, Wheel Pant Cutout

14. Install wheel pant per drawing 4-1474 (rev. L or later).

15. Revise weight and balance data.

7-Series and 8KCAB	Weight	Arm	Moment
Aluminum Gear	30	.75 (2.75 8KCAB)	22.5 (82.5 8KCAB)
Steel Gear	43	.75 (2.75 8KCAB)	32.3 (118.3 8KCAB)

8GCBC	Weight	Arm	Moment
Aluminum Gear	38	.75	28.5
Steel Gear	67	.75	50.3

American Champion Aircraft Corp.
Rochester, WI 53167

Service Letter: 422 Revision "A" (Page 4 of 4)

Date: January 14, 2005

Title: Aluminum Gear Retrofit

Parts Required

Part Number	Description	Qty Req'd 7-Series and 8KCAB	Qty Req'd 8GCBC
4-2035	Aluminum Gear Leg	1L /1R	N/R
4-2041	Aluminum Gear Leg	N/R	1L /1R
MS20007-46	Bolt	N/R	4
MS2007-36	Bolt	N/R	2
MS20007-40	Bolt	2	N/R
MS20007-42	Bolt	4	N/R
MS20002-7	Washer	6	6
MS20002C7	Washer	2	2
BACN10HR7	Nut	6	6
1-8999-1	Plate	A/R	A/R
1-9998-1	Fairing Tube	2	2
11-0967	Wheel Pant Bracket	2	N/R
11-0955	Spacer	2	N/R
*11-0850	U-Bolt Bar	2	2
AN5-22A	Bolt	8	8
2-2111-9	Brake Line	2	2
AN960-516	Washer	8	8
AN365-524	Nut	8	8
AN913-1D	Plug	2	2
AN822-4D	Fitting	4	4
AN-823-4D	Fitting	2	2
601000-4-0080	Hose	N/R	2
601000-4-0094	Hose	2	N/R
9563K84	Plug	2	2
4-1474	Wheel Pant Install. Drawing	1	N/R
7-1559	Gear Install. Drawing	1	N/R
7-1779	Gear Install Drawing	N/R	1
*Only if not installed previously			

Approval: Drawings and data within this service letter are FAA approved via ACAC technical drawings. Gear leg serial numbers and retrofit, in accordance with drawings 4-1474, 7-1559 (7-1579 for 8GCBC), and SL 422, should be called out in an aircraft logbook entry. Installation prints are available for sale and should be kept with airplane records.