

American Champion Aircraft Corp.  
Rochester, WI 53167

Service Letter: 430, Revision A

1 of 4

Date: March 05, 2008

Title: Conversion of 7ECA, 7GCAA and 7GCBC to Lycoming O-320-B2B or Equivalently Provisioned Engine per TCDS E-274.

Models: 7ECA, 1974 Models and Up  
7GCAA and 7GCBC, 1974 to 1980 Models

Description: This service letter outlines the procedures necessary to upgrade the following models to an O-320-B2B (160 HP) engine:  
7ECA with an O-235-C1 (108 HP) or O-235-K2C (118 HP) engine  
7GCAA with an O-320-A2B, O-320-C2B or O-320-A2D (150 HP) engine  
7GCBC with an O-320-A2B, O-320-C2B or O-320-A2D (150 HP) engine

Wings and Struts (Original Equipment for 7ECA, 1994 and Up)

The installation of the O-320-B2B engine requires ACAC metal spar wings. Install wings and struts per ACAC drawing 7-1568 (7ECA, 7GCAA) or 7-1546 (7GCBC).

Major Components Required:

7-1567 L/R Covered Wings (7ECA, 7GCAA)

7-1545 L/R Covered Wings (7GCBC)

5-433 Front Struts

11-0848 Front Jury Struts

Electrical

Modify electrical system per Service Letter 418 or revise installation per ACAC drawing 4-1782.

Reference ACAC drawing 4-1791 for wiring schematic. For model 7ECA, install (1) 2-2080 battery bracket, (1) 1-2451 ground lug and (5) 1-2270-1 starter cable lugs per ACAC drawing 7-1290.

Major Components Required:

RG-25 Battery

4-1995 Battery Box

Fuel System (Original Equipment for 7ECA, 1994 and Up)

Replace and relocate gascolator. See figure 1 for correct placement of the new gascolator. Replace carburetor fuel line with Aeroquip hose 624000-8D-0154. Replace fuel valve bracket with 11-0831 per ACAC drawing 7-1290. Components from the gascolator to and including the fuel manifold must also be replaced; install components per ACAC drawing 7-1476.

Major Components Required:

624000-8D-0154 Fuel Line (Gascolator to Engine)

2-2219 Gascolator

2-2258 Fuel Line (Gascolator to Manifold)

2-2198 Manifold Sub-Assembly

2-2088-1 Fuel Shutoff Bracket

11-0658 Fuel Shutoff Handle

American Champion Aircraft Corp.  
Rochester, WI 53167

11-0831 Fuel Valve Bracket

Firewall

The existing 4-1640 firewall must be modified with the addition of the three hole patterns shown in figure 1, or replaced with a new 4-1640-4 firewall. Plug any unused holes with 1-8864-6 cover, 1-8865-4 silicone washer and AS6-4-6SP screws.

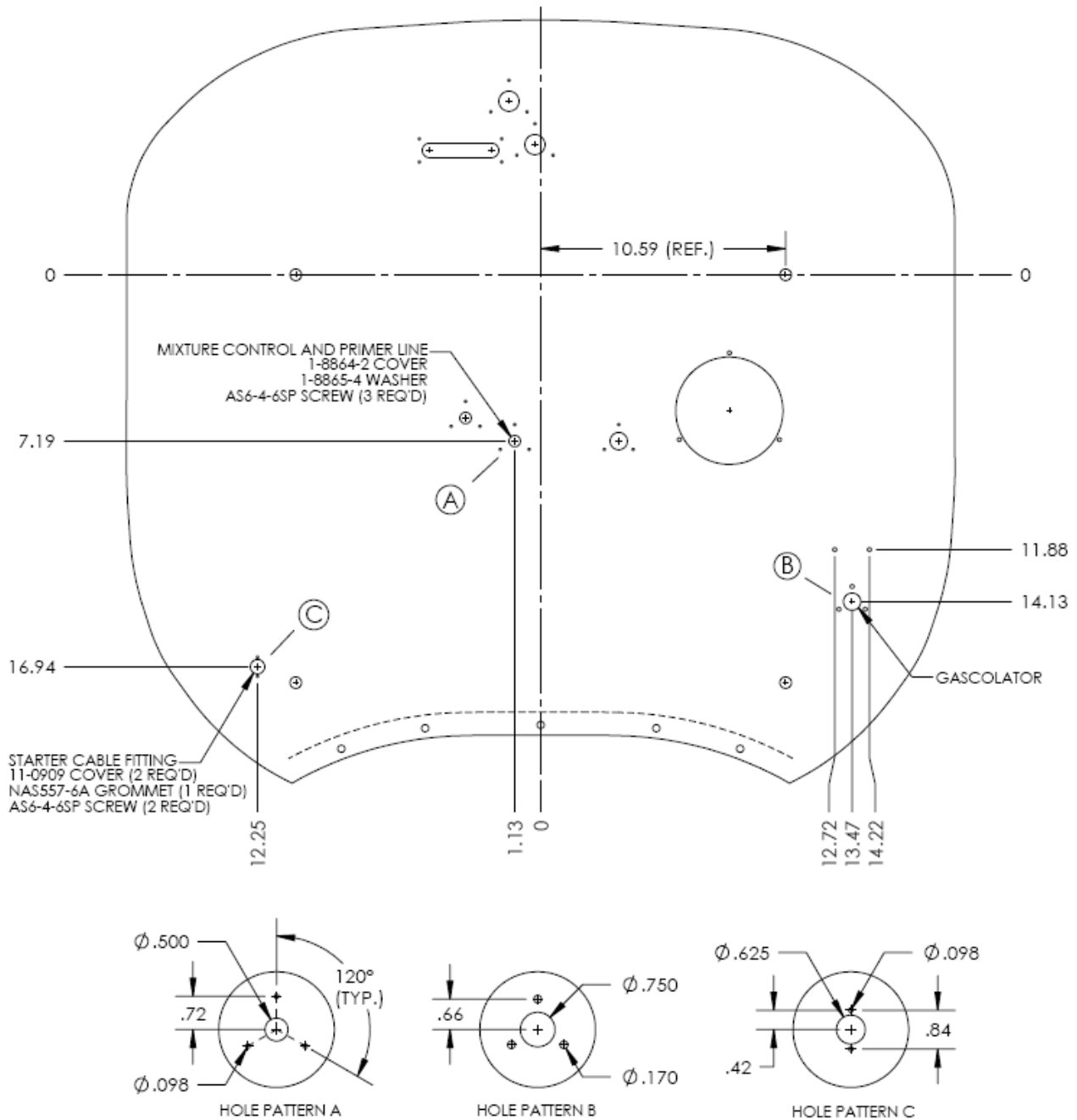

Figure 1, Firewall Modifications

American Champion Aircraft Corp.  
Rochester, WI 53167

Service Letter: 430, Revision A

3 of 4

Power Plant

Replace engine, engine mount and propeller. Install per ACAC drawing 7-1289. Tachometer must be replaced or range markings must be modified as follows; 1800 to 2700 RPM green arc, 2700 RPM red radial line.

Major Components Required:

O-320-B2B Lycoming Engine  
74DM6S8-1 Sensenich Propeller  
7-1522-2 Engine Mount

Approval

The figures and data contained within this service letter are FAA approved via the following ACAC technical drawings:

<u>Drawing</u>	<u>Title</u>	<u>Revision</u>	<u>Date</u>
11-1029	Engine Conversion 7ECA	No rev. or later	3-04-08
4-1640	Firewall Blank	AB or later	7-12-07
4-1782	Battery Installation	L or later	9-08-03
4-1791	Electrical System Schematic	M or later	5-29-07
7-1289	Engine Installation	L or later	8-27-04
7-1290	Fuselage Frame Ass'y	G or later	7-31-00
7-1476	Fuel System Installation	H or later	8-09-04
7-1516	Firewall Sub-Ass'y	I or later	5-10-04
7-1546	Wing and Strut Installation	I or later	9-14-04
7-1568	Wing and Strut Installation	G or later	8-21-03

Engine retrofit must be recorded in the engine logbook, aircraft logbook and on a FAA Major Repair and Alteration Form 337. There may be instances where deviation from this service letter may be desirable or necessary. This service letter is intended to be completed in whole; if deviations are necessary they must be recorded and approved as additional items on the 337 form.

Sample Engine Logbook Entry:

- *Installed Lycoming O-320-B2B serial number \_\_\_\_\_ in accordance with ACAC drawing 7-1289, rev. L, dated 8-27-04.*

Sample Aircraft Logbook Entry:

- *Modified aircraft in accordance with SL430, reference FAA Form 337 dated \_\_\_\_\_.*
- *Installed 7-1567 wings serial number \_\_\_\_\_ in accordance with ACAC drawing 7-1568, rev. G, dated 8-21-03. (7ECA, 7GCAA)*
  - OR -
  - *Installed 7-1545 wings serial number \_\_\_\_\_ in accordance with ACAC drawing 7-1546, rev. I, dated 9-14-04. (7GCBC)*
- *Installed 2-2219 gascolator in accordance with ACAC drawing 7-1476, rev. H, dated 8-9-07.*
- *Modified electrical system in accordance with SL418.*

American Champion Aircraft Corp.  
Rochester, WI 53167

- Installed battery in accordance with ACAC drawing 4-1782, rev. L, dated 9-8-03. (7ECA)  
Service Letter: 430, Revision A

4 of 4

Sample 337 Text:

- Installed Lycoming O-320-B2B serial number \_\_\_\_\_ and Sensenich propeller 74DM6S8-1 serial number \_\_\_\_\_ in accordance with ACAC drawing 7-1289, rev. L, dated 8-27-04 and Service Letter 430.
- Installed 7-1567 wings serial number \_\_\_\_\_ and 5-433 front struts in accordance with ACAC drawing 7-1568, rev. G, dated 8-21-03. (7ECA, 7GCAA)
- OR -  
Installed 7-1545 wings serial number \_\_\_\_\_ and 5-433 front struts in accordance with ACAC drawing 7-1546, rev. I, dated 9-14-04. (7GCBC)
- Weighed aircraft, weight and balance updated \_\_\_\_\_.

Service Instructions

Components installed with this service letter should be maintained in accordance with ACAC Service Manual *Citabria Models 1994 and Newer* issued May 11, 2001. For 1974 to 1980 models, all remaining components should continue to be maintained in accordance with Bellanca Service Manual *Citabria Models 1974 to 1980* issued May 01, 1979. For 7ECA models 1994 and up, all components should continue to be maintained in accordance with ACAC Service Manual *Citabria Models 1994 and Newer* issued May 11, 2001.

Refer to *Lycoming Operator's Manual 60297-30* and *Lycoming Overhaul Manual 60294-7* for additional instructions for continued airworthiness.

Refer to *Sensenich Propeller Log Book* and *Sensenich Repair Manual SPRM 590* for additional instructions for continued airworthiness.

Instructions for Continued Airworthiness: The O-320-B2B installation has no additional instructions for continued airworthiness beyond the maintenance and inspections specified in the ACAC service manuals and the publications referenced above.

Flight Manual

A Supplemental Flight Manual is required for aircraft modified in accordance with this service letter. The supplement contains operating limitations necessary for the O-320-B2B and should be attached to the existing flight manual. This combined manual is required to be carried on board the aircraft in accordance with FAR 91.9. Aircraft not originally equipped with a flight manual must also carry the supplemental flight manual. In this case the supplement is in addition to the operating information stated in the form of placards and markings.

ACAC weight and balance worksheet 78-5 (7GCBC), 78-6 (7GCAA) or 78-7 (7ECA) and the associated moment diagram and loading envelope should be attached to the flight manual.